

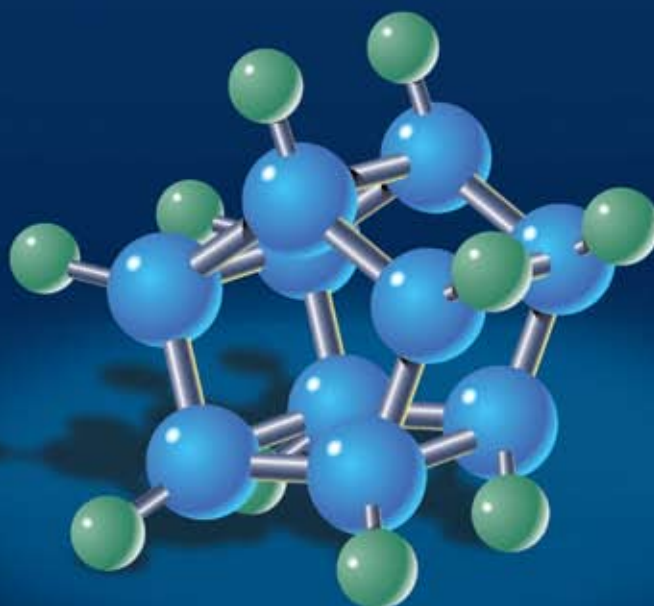

 **ChemGenes**  
CORPORATION

Experience Nucleic Acid  
Expertise



ChemGenes has been in business for over 25 years and has recently moved into a state of the art facility in Wilmington, MA. ChemGenes has a full scale modernized lab with the facilities to manufacture in bulk while maintaining its high quality. We have added many new products to our original line to facilitate research in the area of biotechnology.

As the market for oligonucleotides continues to grow, ChemGenes remains committed to introducing novel products, while maintaining its existing product mix. We also have the capacity to custom synthesize products on request.

**Our quality is guaranteed!** We want to assure you that every product is of the highest purity and conforms to the technical data sheet that accompanies it when shipped.

- ChemGenes takes pride in a long history of customer satisfaction in supplying phosphoramidites that have a purity of 98 % or better for most phosphoramidites.
- Each lot of Phosphoramidite must pass an established testing criteria before it can be shipped to customers.

#### Required QC Tests for Most Phosphoramidites

##### Solubility test

- Amidites completely Dissolve in Acetonitrile to make a 0.1M Solution (water<0.004-0.005gm/100ml). Leave no visible particulate matter.

##### Coupling Efficiency

- The coupling efficiency of ChemGenes phosphoramidite products are 98 % or better.

##### TLC

- Single or double spot with no other visibly impurity on spotting, 0.2mg/spot.
- Single spot or double spot depends on the phosphoramidite.

##### HPLC

- Greater than 98.5 % purity by HPLC.

##### <sup>31</sup>P NMR

- Doublet peak or single peak.
- Position of each peak is know for each phosphoramidite.
- The value between the peaks is calculated and recorded.

**UV** – The UV test provides 4 values of data:

- The ratio between 250/260 nm.
- The ratio between 260/280 nm.
- Emax position.
- Extinction Coefficient.

##### MASS Spectrum

- Performed on each product in +ve and -ve modes.

##### <sup>1</sup>H NMR

- Proton NMR analysis is performed for each product.

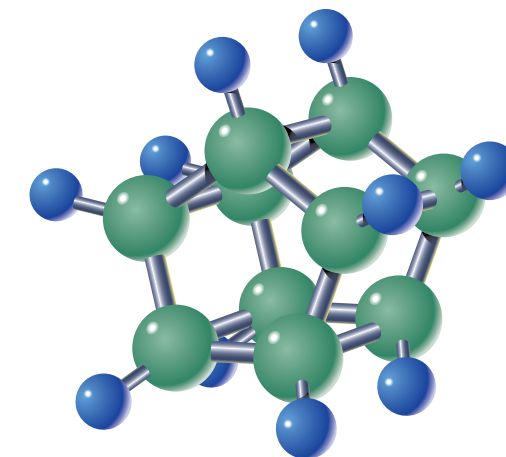
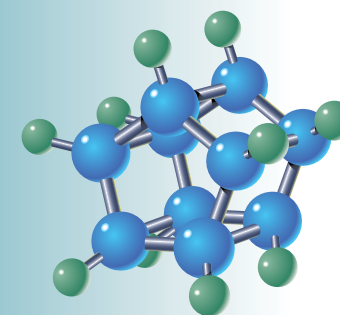

## Our Products

### Oligo Synthesis Reagents

Natural DNA Amidites & Supports  
Ancillary Reagents  
Modified DNA Amidites & Supports  
Natural RNA Amidites & Supports  
Amidites and Supports for Introducing Chromophores & Ligands  
Amidites and Supports for 2'-O-Methyl Oligonucleotides

### Drying Traps

### Oligonucleotide Purification

### Nucleosides, Sugars, Purines, & NHS Esters

Unprotected mononucleosides  
N-protected mononucleosides  
DMT-protected mononucleosides  
Phosphoramidite Chemistry Reagents  
Sugars & Purines  
NHS-Esters

### Trisphosphates

Modified Triphosphates

### Custom Synthesis

### New Featured Products

Universal Support  
TOM Amidites

# TOM Phosphoramidites

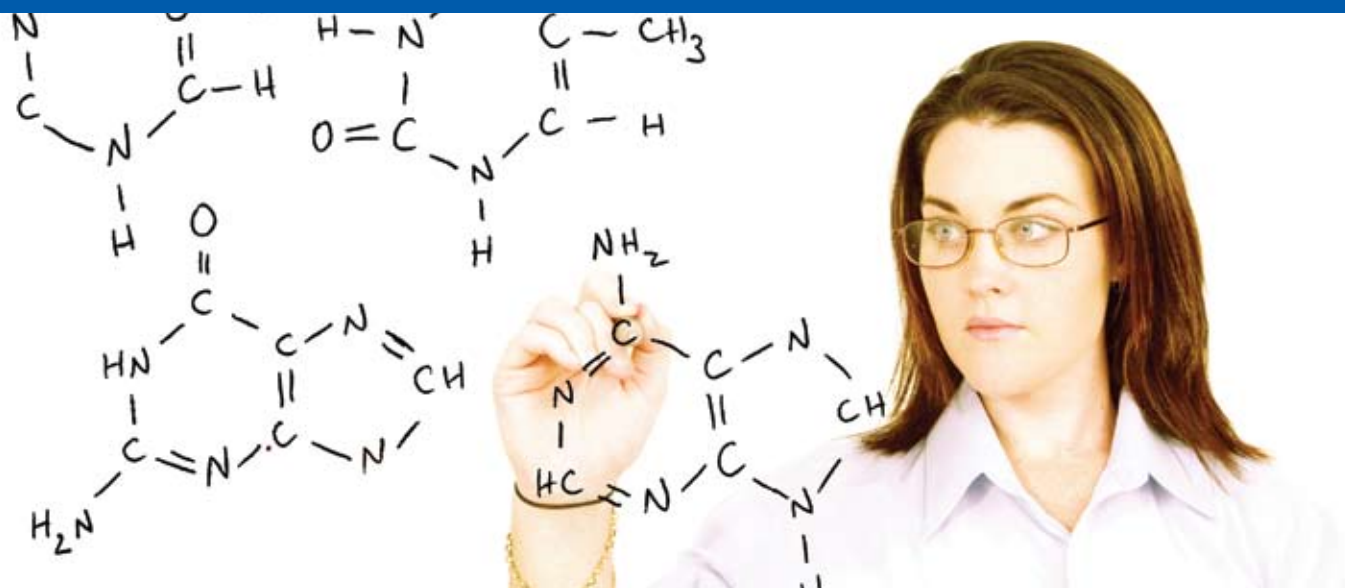

- **Now available in Bulk Quantity for RNA Therapeutics development**
- Superior Quality RNA using 2'-O-TOM Protection
- Perfected Manufacturing Process Allows for Prices Comparable to TBDMS
- Higher Coupling Efficiency Due to lower steric hindrance
- Faster Coupling Times. (2-4 minutes, varies based on scale and activator)

- **Quality Guaranteed**
- Purity greater than 97% by HPLC
- UV Spectral data to conform to highest
- 1 H NMR & 31 P NMR data to conform
- Coupling efficiency greater than 98%
- Produced under GMP guidelines

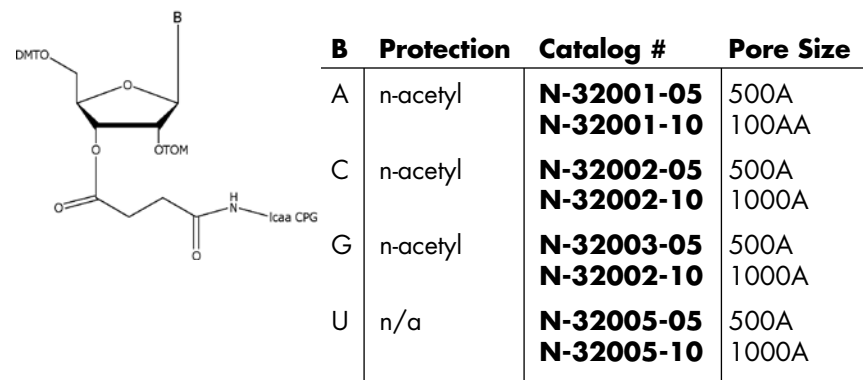
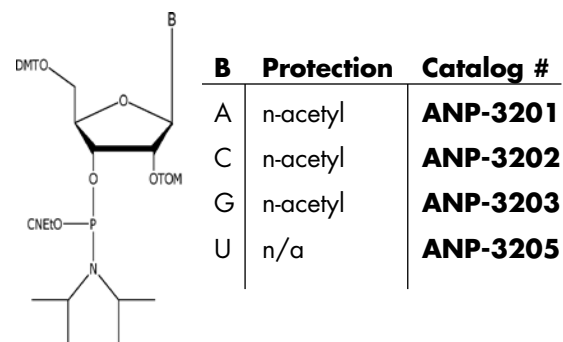

**Low to High loading CPG supports with TOM-monomer for uniform deprotection of RNAs.**

# Universal Supports

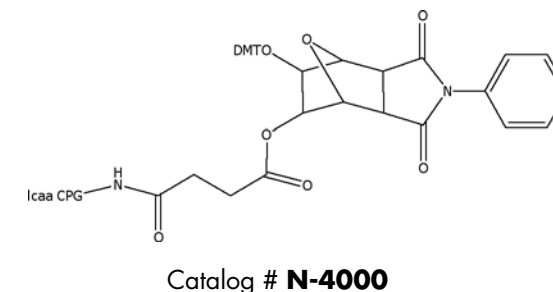
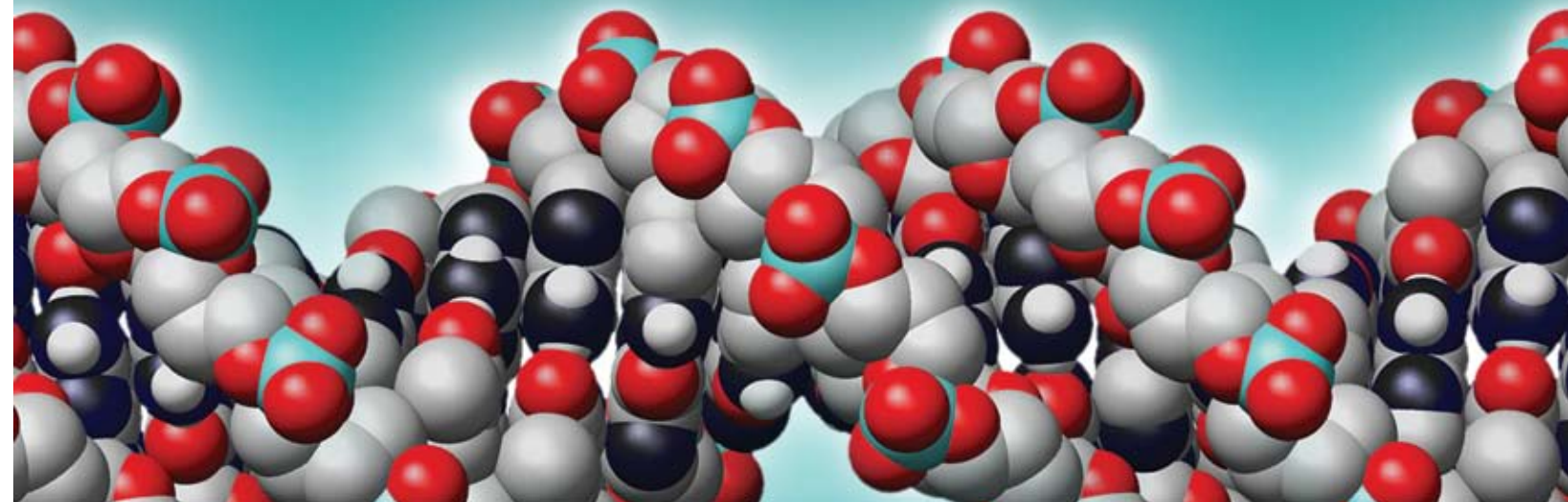

- Fully compatible with standard phosphoramidite reagents and synthesis conditions
- Has standard DMT group and requires standard de-block solutions to start and oligonucleotide synthesis
- Coupling efficiency  $\geq 99\%$
- Results in 3'-OH oligonucleotides
- Has standard succinate linkage and so cleavage from support is quantitative during ammonia incubation

## Applications of UnyLinker Support - Compatible with synthesis of:

DNA Oligonucleotides, Phosphorothioates, 2'-O-alkyl oligonucleotides, LNA oligonucleotides, siRNA oligonucleotides in combination with Cpep protection, Biotin and Fluorescein (FAM).

## Cleavage and Deprotection:

- No Need to add/use
- Salts like LiCl or NaCl
- Stronger nucleophiles like 40% aqueous methylamine solution
- Heavy metals
- Sulfides

**No base Modification is observed (based on Ion Pair LC-MS; detection limit = 0.01%)**

## Inherent Advantage of UnyLinker Molecule

- Conformationally syn-oriented to effect fast cleavage

# 7-Deaza products

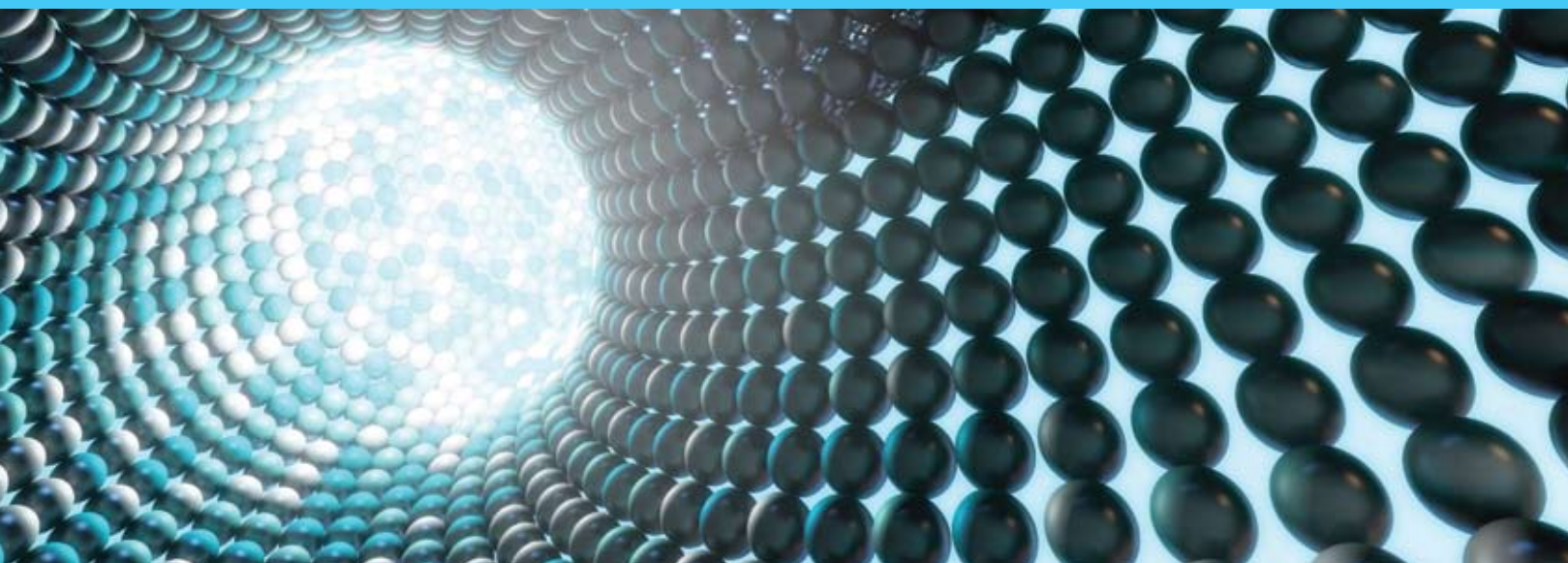

**ChemGenes has perfected the technology of productions of these modified bases and the corresponding phosphoramidites.**

These modifications find extensive application in the design and selection introduction of these modified bases into DNA. Some of the key properties of the 7-deaza modification are outlined:

- Avoids the problem of extensive secondary structure formation, and thereby improves the targeted hybridization.
- Antiparallel triple helix formation with double stranded DNA is favored with this modification.
- The nucleoside and corresponding triphosphates are currently used in DNA sequencing analysis.

**ChemGenes has extensive capabilities in the following:**

- Bulk quantities of the 7-deaza-2'-deoxy nucleosides for DNA sequencing and molecular biology studies.
- Highest purity 7-deaza-2'-deoxy nucleoside phosphoramidites for specific introduction of these modified bases into synthetic DNA sequences.

ChemGenes currently has available the nucleosides; 7-Deaza-r-adenosine, 7-deaza-r-guanosine and 7-deaza-r-inosine, as well as the corresponding 2'-tBDSilyl phosphoramidites.

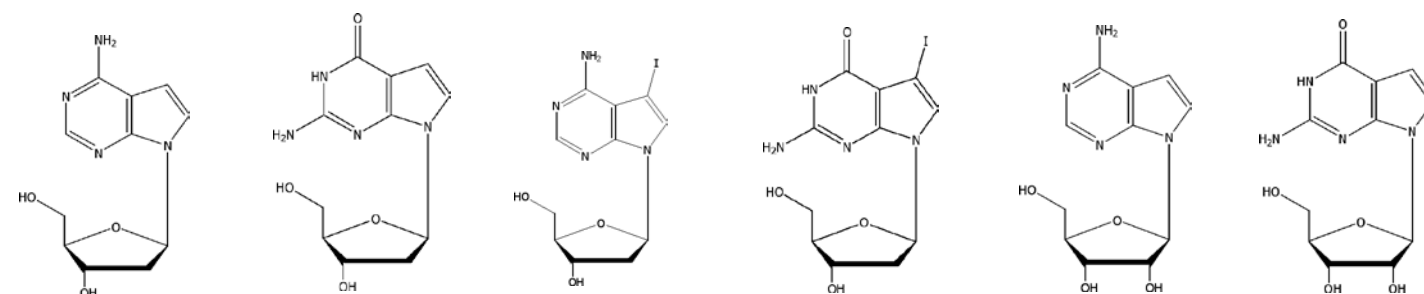

N1-Methyl 7-Deaza deoxy Adenosine

Catalog # **DN-1143**

N1-Methyl 7-Deaza deoxy Guanosine

Catalog # **DN-4567**

7-Deaza-7-Iodo deoxy Adenosine

Catalog # **DN-2561**

7-Deaza-7-Iodo deoxy Guanosine

Catalog # **DN-2563**

7-Deaza ribo Adenosine

Catalog # **RP-2312**

7-Deaza ribo Guanosine

Catalog # **RP-2313**

# N-Alkylated Phosphoramidites

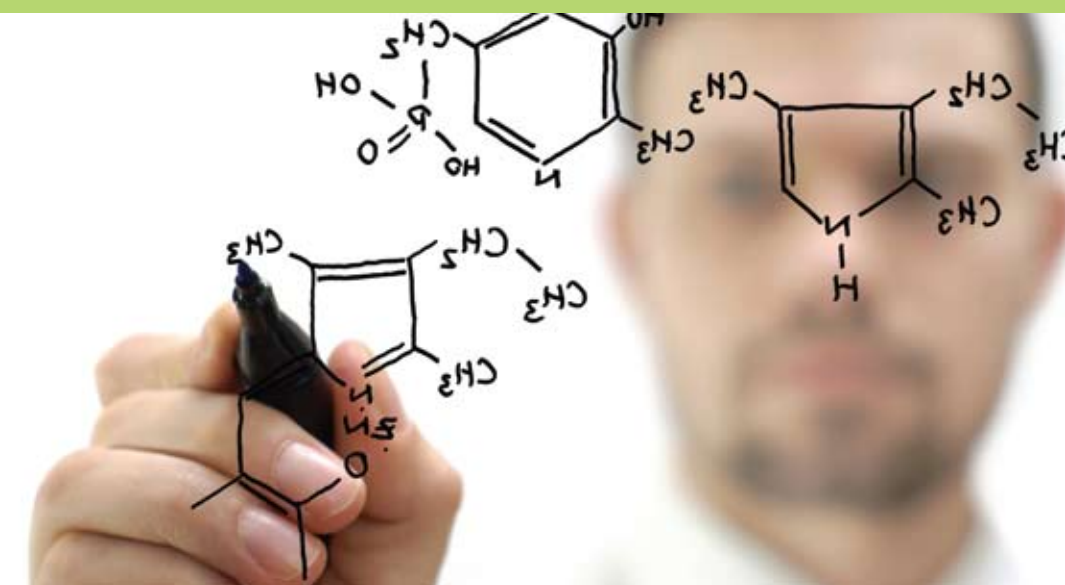

- ChemGenes offers the phosphoramidites for studies and possibilities of reversal of methylated lesions by use of oligonucleotides incorporation alkylated purine/pyrimidine.
- Due to mutagenic effects of carcinogens, DNA in living organisms is vulnerable to alkylation.
- It has been shown that there is a direct reversal of n-alkylation of methylated bases in oligonucleotides.
- The discovery of an enzyme which is substrate for DNA repair has great implications for repair of such carcinogenic and mutagenic effects.

**Our featured products include:**

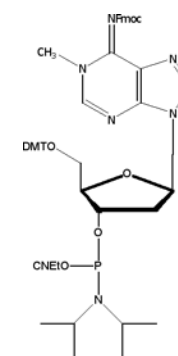

N1-Methyl deoxy Adenosine Phosphoramidite

Catalog # **ANP-6121**

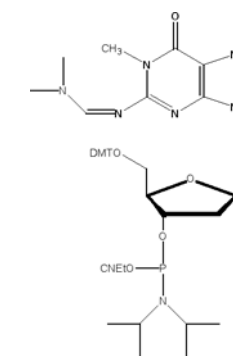

N1-Methyl deoxy Guanosine Phosphoramidite

Catalog # **ANP-6122**

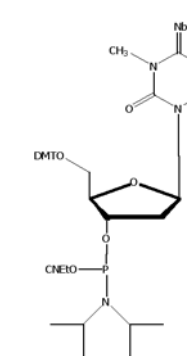

N3-Methyl deoxy Cytidine Phosphoramidite

Catalog # **ANP-3851**

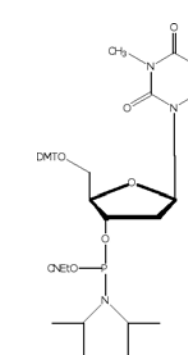

N3-Methyl Thymidine Phosphoramidite

Catalog # **ANP-6153**

*[S.C. Trewick, T.F. Henshaw, R.P.Hausinger, T. Lindahl and B. Sedgwick, Nature, 419, 174-177, 2002; and another report confirming these observations, P.Falnes, R.F. Johansen, E. Seeberg, Nature 419, 178, 2002].*

# 3'-tBDSilyl RNA Phosphoramidites

# Reverse Oligo Synthesis

- Allows the synthesis of 2'-5'-linked oligos
- RNA 2',5'-duplexes are not substrates of the enzyme RNase. However, they can inhibit the RNaseH mediated cleavage of a natural DNA: RNA substrate.

## Useful Applications:

- Determine their exact biological role
- Extend their biological half life
- Alter the biological activity of the core structure

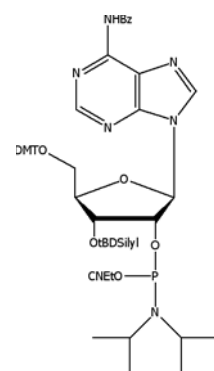

Adenosine (n-bz) 3'-tBDSilyl  
CED OP

Catalog #  
**ANP-5681**

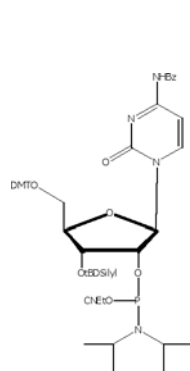

Cytidine (n-bz)  
3'-tBDSilyl CED OP

Catalog #  
**ANP-5682**

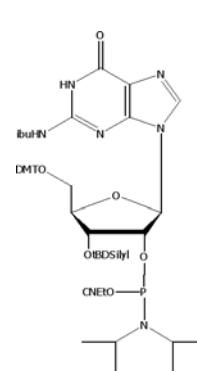

Guanosine (n-ibu) 3'-tBDSilyl  
CED OP

Catalog #  
**ANP-5683**

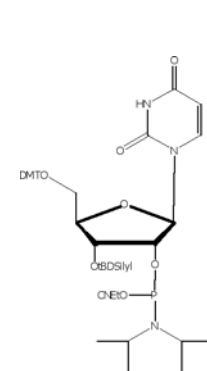

Uridine 3'-tBDSilyl CED OP

Catalog #  
**ANP-5684**

- ChemGenes offers reverse amidites with 5',3'-direction of synthesis
- Including reverse 2'-O-Methyl amidites, Reverse Abasic Amidite, Reverse deoxy Amidites, and more....

## Application of Reverse Phosphoramidites

- Synthesis of 3'-3'-linked DNA
- Synthesis of special oligonucleotides required to be coupled at the 5'-end selectively
- Synthesis of oligonucleotides from left to right (5'-3'-direction)

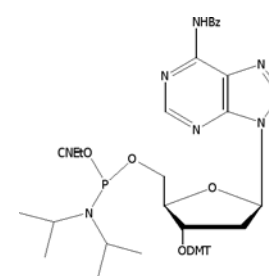

3'-DMT deoxy Adenosine  
(n-bz) 5'-CED OP

Catalog # **ANP-4671**

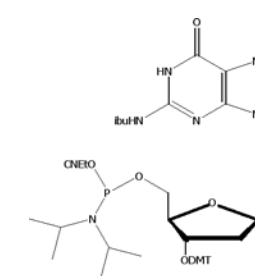

3'-DMT deoxy Guanosine  
(n-ibu) 5'-CED OP

Catalog # **ANP-4673**

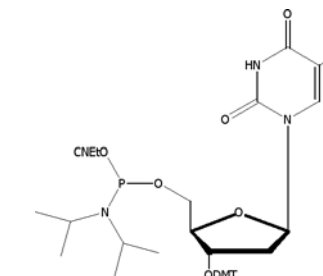

3'-DMT Thymidine  
5'-CED OP

Catalog # **ANP-4674**

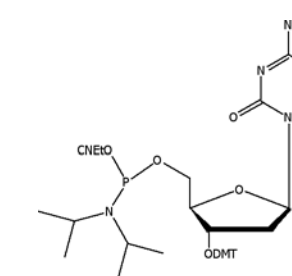

3'-DMT deoxy Cytidine  
(n-bz) 5'-CED OP

Catalog # **ANP-4672**

- Also available are reverse 2'-O-Methyl RNA

B	Protection	Catalog #
A	n-bz	<b>ANP-1012</b>
C	n-bz	<b>ANP-1013</b>
G	n-ibu	<b>ANP-1014</b>
U	n/a	<b>ANP-1015</b>

# 2'-O-Methyl Antisense Products

www.CHEMGENES.com

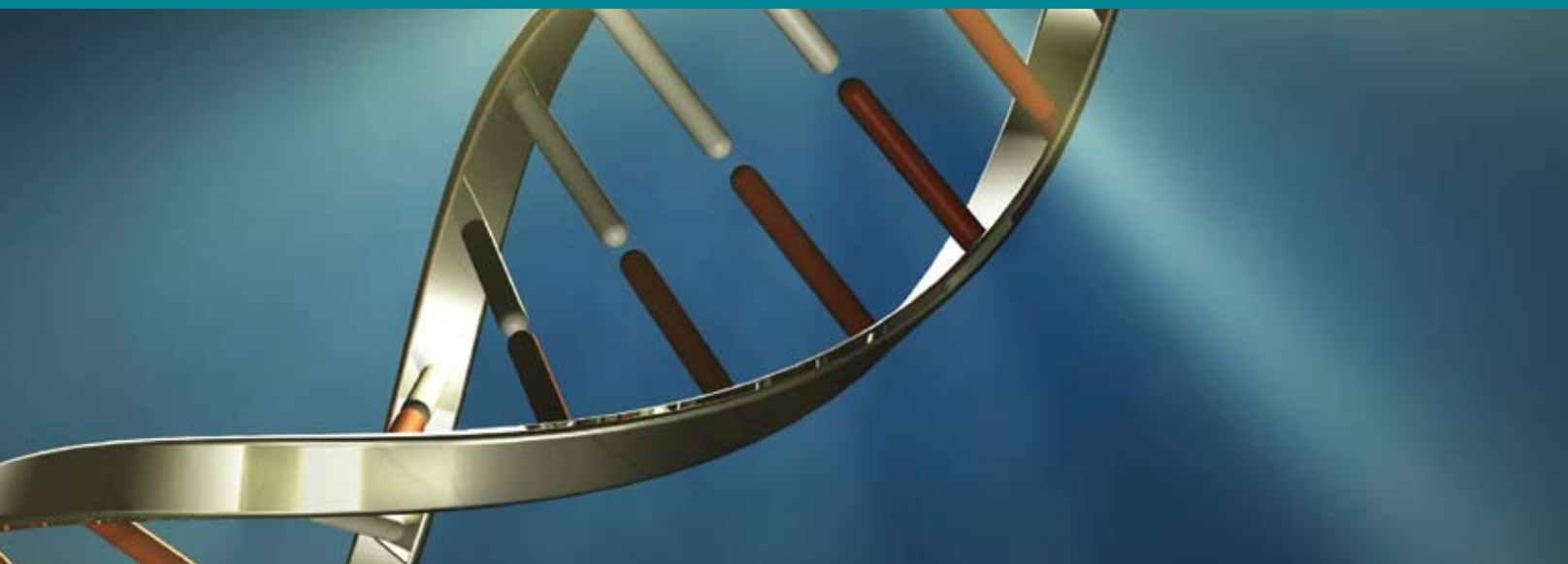

ChemGenes offers an extensive line of 2'-O-Methyl Modified Phosphoramidites for Molecular Biology applications such as increased lipophilicity, amphiphilicity, nuclease resistance, improves Tm and higher specificity and reduced G-C clamping.

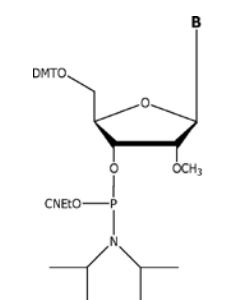

Natural 2'-O-Methyl

B	Protection	Catalog #
A	n-bz	<b>ANP-5751</b>
C	n-ac	<b>ANP-6756</b>
G	n-ibu	<b>ANP-5753</b>
U	n/a	<b>ANP-5754</b>

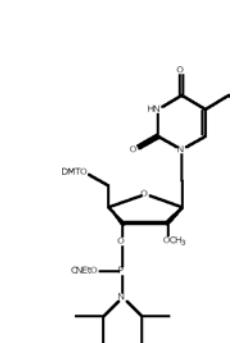

2'-O-Methyl 5-Methyl Uridine (ribo Thymidine) CED OP

Catalog # **ANP-5600**

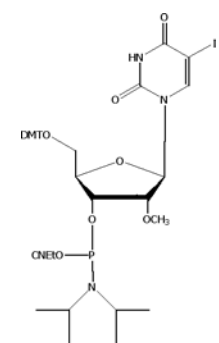

5-Iodo Uridine 2'-O-Methyl CED OP

Catalog # **ANP-5759**

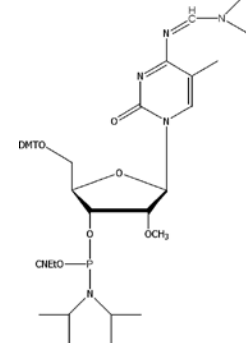

5-Methyl Cytidine (n,n-dmf) 2'-O-Methyl CED OP

Catalog # **ANP-6554**

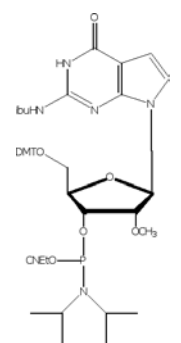

7-Deaza-2'-O-Methyl Guanosine CED OP

Catalog # **ANP-5953**

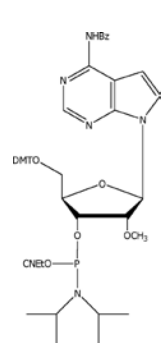

7-Deaza-2'-O-Methyl Adenosine CED OP

Catalog # **ANP-5951**

### Licensing & Trademarks

These products are made and sold under license from: Ajinomoto Co., Inc. under Patent No. 5,013,830 & ChemGenes Corp. under Patent No. 5,214,135.



New and improved features. Visit [www.chemgenes.com](http://www.chemgenes.com)!

**\*NEW\*** Log in and place orders using our new e-commerce based ordering system.

Our Search engine has been revamped and enhanced so finding products at chemgenes.com is quick and easy.

Navigating through ChemGenes' website is much easier with products categorized in an organized and convenient fashion. View chemical structures, product properties, and more...

**\*NEW\*** Tech Library

Quick lists of links to our newest and most popular products.

With over 20 years of experience in the field of DNA/RNA chemistry, ChemGenes bulk produces superior quality standard & modified phosphoramidites and nucleosides.

**\*NEW\*** Custom Products Page: ChemGenes has successfully produced a large variety of high quality phosphoramidites and nucleosides on a custom basis. Use our new Custom Products page to submit your custom product request.



 **ChemGenes**  
CORPORATION

33 Industrial Way  
Wilmington, MA 01887 USA

Tel: 978-694-4500  
Fax: 978-694-4502  
Toll Free: 800-762-9323  
Email: [info@chemgenes.com](mailto:info@chemgenes.com)

[www.chemgenes.com](http://www.chemgenes.com)